



Hardinge FlexC™ Dead-Length® Collet System Style A

Installation Instructions
and Parts Lists

General Safety Information

Before installing the Hardinge® FlexC™ Collet System on your machine tool, thoroughly read this manual and understand the information. If you are uncertain about any of the information, see your immediate supervisor. Also make certain that you understand the information in your machine tool operator's, programmer's and maintenance manuals.

NOTICE

**Damage resulting from misuse, negligence or accidents
is not covered by the Hardinge FlexC warranty.**

Information in this document is subject to change without notice.

**In no event will Hardinge Inc. be responsible for indirect or consequential damage
resulting from the use or application of the product, or any of the information in this document.**

**This product is only to be used by trained machinists skilled
in the use and operation of collet systems and collet chucks on metal cutting machines.**

Safety Requirements to the Turning Machine:

Check to see that the workpiece is properly gripped and seated in the collet head before beginning the machining cycle.

Do not unclamp the workpiece until the machining cycle has come to a complete stop.

Observe all safety precautions indicated in the machine manual when operating the machine including the use of guards and keeping the door closed during machining.

Do not exceed the maximum operating force and rpm for the Hardinge FlexC Collet Systems indicated below:

Maximum operating force: 10,100 lb (45KN)

Maximum RPM: 6,000

Product Description and Use:

The Hardinge FlexC Style A Collet System consists of a spindle mount assembly. Vulcanized collet heads and wrenches are purchased separately. The Style A Dead-length® Collet System can be used with a thru-hole for bar work or with a work stop for chucking. The clamping heads consist of hardened steel segments that are joined together by a vulcanization process. Their outstanding characteristics include parallel workpiece clamping, superb accuracy with a minimum of deformation of the work piece, and quick-change capability. If the Hardinge FlexC Style A Collet System is used as a dead-length system the work stop is inserted into the body with a custom-manufactured work stop. When part length control is not required the work stop can be removed and a protective ring will be inserted in its place.

The Hardinge FlexC Style A Collet System is a pull-back system. The collet draws in against a stationary work stop for part length control providing very stable gripping of the workpiece. The overall rigidity of the entire gripping unit has a very positive effect on tool wear. You can "short grip" parts by machining a special work stop to the desired length.

CAUTION: Make sure that the workpiece is adequately gripped so that the workpiece will not come loose during the machining process. When clamping very short workpieces, the minimum clamping lengths must be observed. They depend on the selected clamping head size and shape – call Hardinge for guidance. Do not clamp tapered work pieces. In general the collet system should never be rotated without a clamped workpiece. When actuating the changing wrench, never reach inside the moving parts for risk of severely damaging your hand.

Drawbar Linkup

The Hardinge FlexC Collet System requires a drawbar linkup to mate the specific machine drawbar (varies by machine brand and model) to the FlexC collet seat. This linkup can be ordered from Hardinge or can be made by the customer. The linkup should be screwed on the end of the drawbar before beginning installation of the FlexC Collet system.

Cleaning and Maintenance

The spindle, collet head and the spindle mount mating surfaces must be cleaned and free of chips and sludge whenever mounting to the spindle or changing out a collet head. Do NOT clean an open spindle with an air hose as chips and sludge may be forced into the spindle drawbar area. Clean and lubricate all moving parts with Chevron Ultra-Duty EP NLGI 2, Dow Corning BR-2-Plus, or Kluber ALTEMP Q NB 50 grease. Store all unused products properly to prevent corrosion and keep free of dust and environmental particles.

Check to see that all mounting screws are in good condition and replace when worn. All components must be replaced with original Hardinge replacement parts.

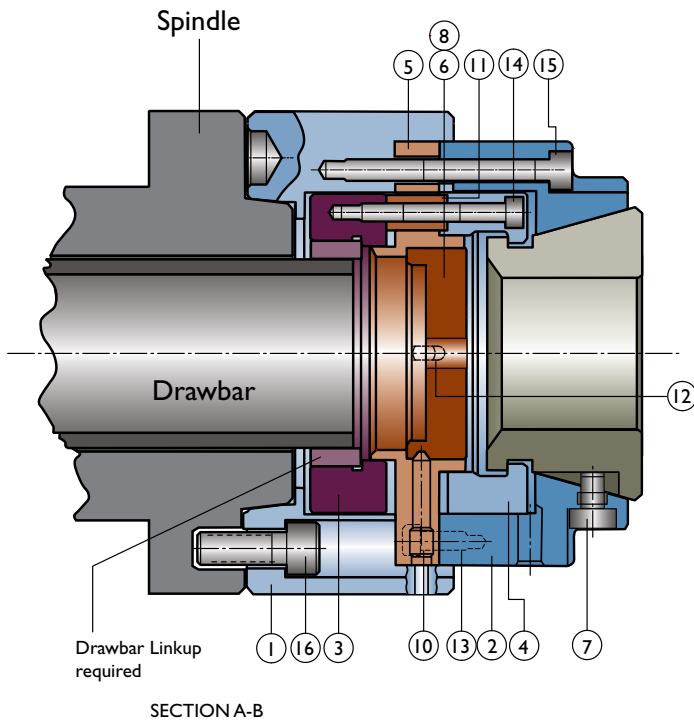

A2-6 Assembly #V65-6A01300 Parts List:

ITEM	PART NO.	QTY	DESCRIPTION
1	V65-6A01301	1	Spindle Adapter
2	V65-6A01202	1	Collet Seat
3	V65-6A01203	1	Drawbar Adapter
4	V65-6A01204	1	Clamping Sleeve
5	V65-6A01205	1	Work Stop Adapter
6	V65-6A01206	1	Work Stop
7	V65-01207	1	Key for Collet Head
8	V65-6A01210	1	Protective Ring
10	V65-6A01008	3	Lock Pin
11	V65-6A01009	12	Spacer
12	V65-01603	1	Locating Stud
13	MS-0103617	2	M6x16 SHCS
14	MS-0103624	12	M6x50 SHCS
15	MS-0103827	4	M8x65 SHCS 26ft-lb/36Nm
16	MS-0104220	4	M12x30 SHCS 90ft-lb/122Nm

A2-8 Assembly #V65-8A01400 Parts List:

ITEM	PART NO.	QTY	DESCRIPTION
1	V65-8A01401	1	Spindle Adapter
2	V65-6A01202	1	Collet Seat
3	V65-6A01203	1	Drawbar Adapter
4	V65-6A01204	1	Clamping Sleeve
5	V65-6A01205	1	Work Stop Adapter
6	V65-6A01206	1	Work Stop
7	V65-01207	1	Key for Collet Head
8	V65-6A01210	1	Protective Ring
10	V65-6A01008	3	Lock Pin
11	V65-6A01009	12	Spacer
12	V65-01603	1	Locating Stud
13	MS-0103617	2	M6x16 SHCS
14	MS-0103624	12	M6x50 SHCS
15	MS-0103827	4	M8x65 SHCS 26ft-lb/36Nm
16	MS-0104630	4	M16x80 SHCS 200ft-lb/270Nm

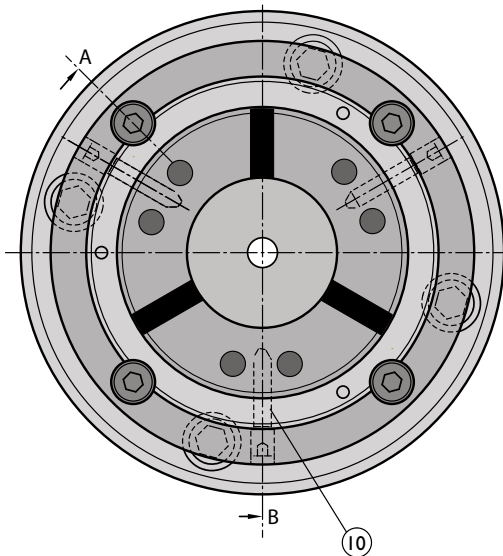

170mm Assembly #V65-170A01800 Parts List:

ITEM	PART NO.	QTY	DESCRIPTION
1	V65-170A01801	1	Spindle Adapter
2	V65-6A01202	1	Collet Seat
3	V65-6A01203	1	Drawbar Adapter
4	V65-6A01204	1	Clamping Sleeve
5	V65-6A01205	1	Work Stop Adapter
6	V65-6A01206	1	Work Stop
7	V65-01207	1	Key for Collet Head
8	V65-6A01210	1	Protective Ring
10	V65-6A01008	3	Lock Pin
11	V65-6A01009	12	Spacer
12	V65-01603	1	Locating Stud
13	MS-0103617	2	M6x16 SHCS
14	MS-0103624	12	M6x50 SHCS
15	MS-0103827	4	M8x65 SHCS 26ft-lb/36Nm
16	MS-0104220	4	M12x30 SHCS 90ft-lb/122Nm

FlexC™ Collet System Style A Instructions B-153

Installation

The spindle adapter and collet seat are shipped assembled. The spindle adapter must be separated from the collet seat by removing the four mounting screws #15. Inspect the six fastening screws #14 to ensure a torque of 7.375 ft-lb (10Nm). Tighten if necessary.

Clean, inspect and grease the machine spindle and the spindle adapter. Mount the spindle adapter to the machine spindle using the four fastening screws #16, orienting the spindle adapter with the drive button. Tighten the fastening screws to the appropriate torque shown in the parts list.

Check the concentricity and face runout of the spindle adapter before mounting the body. Neither should exceed .0002" (5µm). If the indicator reading is more than .0002" (5µm), remove the spindle adapter and clean the surfaces again before remounting.

Reduce the clamping pressure of the machine to a minimum and extend the drawbar to the forward position. Carefully screw the collet seat assembly onto the drawbar clockwise until it bottoms out. **DO NOT TIGHTEN.** Rotate the body counterclockwise until the clearance holes in the body line up with the threaded holes on the spindle adapter. Carefully move the drawbar backwards and seat the body into the spindle mount. Insert and tighten the four mounting screws #15 equally to the appropriate torque shown in the parts list.

Increase the clamping pressure to sufficient force for the job.

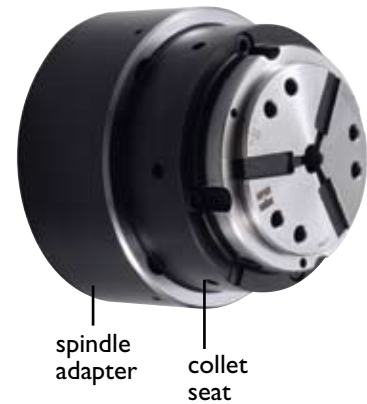

Checking the final Concentricity of the Collet Closing Taper

Locate the probe to touch the inside closing taper of the body to verify concentricity. This should not exceed .0002" (5µm). If the indicator reading is more than .0002" (5µm), remove the body and clean the surfaces of the spindle mount and the body again before remounting. Check the concentricity again and repeat this step until the desired reading is met. Concentricity may be affected if using stock beyond the nominal gripping range.

Installing a Collet Head

Installing or changing of the collet head is possible only when the chuck is in the unclamped position. Prior to inserting the collet head you must clean the taper of the collet seat and the mating taper of the collet head.

Fully insert the pins of the manual wrench into the holes in the face of the collet head. Actuate or pull the lever to collapse the segments before inserting it into the collet seat. Insert applying light pressure. Orient the keyway in the collet head with the key #7 in the collet seat. To release the collet head from the manual wrench you must press on the release button.

CAUTION: When actuating the manual wrench never reach inside the moving parts where there is risk of injury to your hand. Clean and lightly oil the collet head and the collet seat before installing.



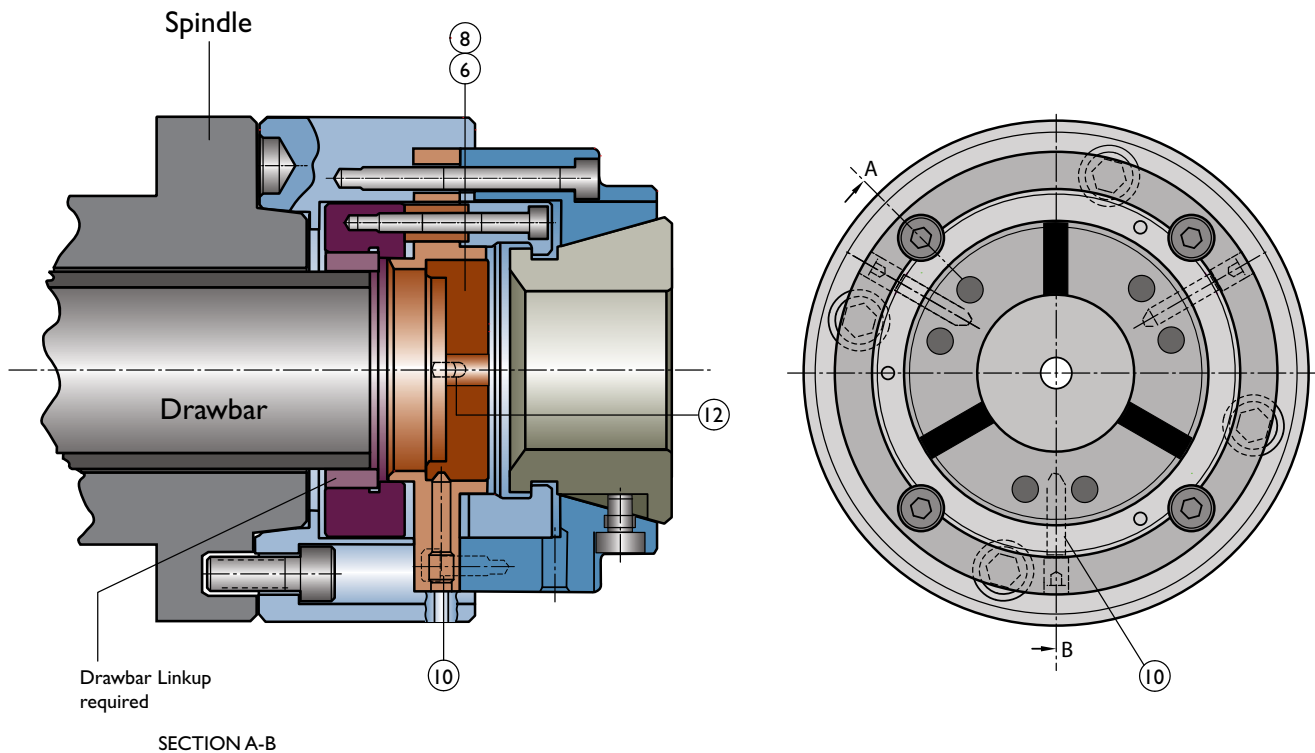

Removing or Changing the Work Stop

Follow the previous instructions to remove the collet head before changing the work stop. The collet head must be in the unclamp position.

To remove the work stop you must turn the three locking pins #10 counterclockwise until you feel resistance.

CAUTION – applying too much force may damage the locking pins. When the locking pins are loose the work stop can be pulled out by threading an M12 screw into the threaded hole in the center of the work stop.

When inserting the work stop ensure that the lateral locating stud #12 in the work stop is flush with the keyway in the work stop. Now carefully turn the three locating pins #10 clockwise until you feel resistance. Hand tightening of the screws is sufficient, do not over tighten. Applying too much force can damage the screws. If you are NOT using the dead-length work stop, the protecting ring #8 must be insert into the collet seat using the same alignments mentioned above.

A custom work stop can be machined by the customer and installed into the M12 thread of the work stop to accommodate various applications. The tapped holes on the face of collet seat can be use to mount a customer machined work stop.